



Hoist With Hook Suspension 0.5Ton-5Ton

Product name: PDH Electric Chain Hoist

Product features:

This product has the durability of long-term operation and high speed lifting. The low noise electric hoist adopt electromagnetic brakes, so that it is even more safe.

It is widely used in various fields because of its reliability.

FEC G80 ultra-treated alloy steel chain which is suitable for rain, sea water and chemical environments.

Standard equipped the up and down limitation contactor, emergency stop switch, so that it is much more safe when lifting.

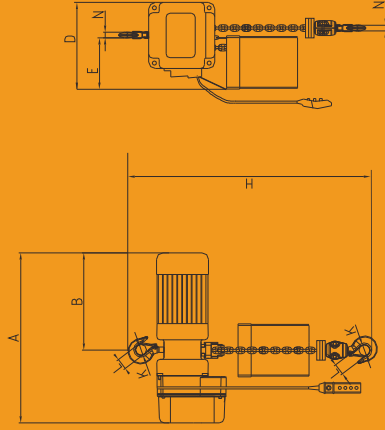

Technical Parameters

Type	PDH-A-0.5	PDH-A-1	PDH-A-2	PDH-A-3	PDH-A-5
Standard Lifting Height (m)	3				
Capacity(t)	0.5	1	2	3	5
Lifting Speed (m/min)	7.2	6	3	6	3.0
Power(Kw)	0.9	1.1	1.1	3.0	3.0
Voltage(v)	110-460				
Frequency(Hz)	50/60				
Chain Turns	1	1	2	1	2
Chain Specification	Φ6.3x19 Φ8x24 Φ11.2x34 Φ11.2x34				
Test Load(T)	0.625	1.25	2.5	3.75	6.25

Size Specification

Type	Capacity(Ton)	Unit(mm)									
		H	A	B	D	E	K	L	N		
PDH-A-0.5	0.5	510	595	320	290	240	Φ40	31	24		
PDH-A-1	1	520	595	320	290	240	Φ40	31	24		
PDH-A-2	2	590	595	320	300	245	Φ49	35	30		
PDH-A-3	3	630	785	395	485	295	Φ59	42	35		
PDH-A-5	5	860	785	395	485	360	Φ60	45	43		