



Hoist With Electric Trolley

0.5Ton-5Ton

Product name: PDH Electric Chain Hoist

Product features:

- Working class is M5, can work for a long time. Small size, light weight, compact housing, excellent protection from water and dust-IP55.
- Braking system: adopting electro magnetic brakes to get high precision.
- High strength gear material is heat-treated and noise range is 60-65db.
- The hoist adopts FEC80 ultra-treated steel chain. Brake device is light, beautiful and durable.

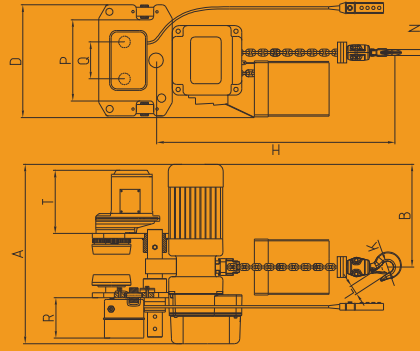

Technical Parameters

Type	PDH-A-0.5	PDH-A-1	PDH-A-2	PDH-A-3	PDH-A-5
Standard Lifting Height (m)	3				
Capacity(t)	0.5	1	2	3	5
Lifting Speed (m/min)	7.2	6	3	6	3.0
Power(Kw)	0.9	1.1	1.1	3.0	3.0
Voltage(v)	110-460				
Frequency(Hz)	50/60				
Chain Turns	1	1	2	1	2
Chain Specification	Φ6.3x19 Φ8x24 Φ8x24 Φ11.2x34 Φ11.2x34				
Test Load(T)	0.625	1.25	2.5	3.75	6.25

Size Specification

	Capacity(Ton)	Unit(mm)										
		H	A	B	D	K	L	N	R	T	P	Q
PDH-A-0.5	0.5	390	595	320	300	Φ40	31	24	142	231	206	111
PDH-A-1	1	400	595	320	300	Φ40	31	24	142	231	206	111
PDH-A-2	2	580	595	320	300	Φ49	35	30	142	231	237	127
PDH-A-3	3	620	785	395	520	Φ59	42	35	142	231	265	140
PDH-A-5	5	860	785	395	580	Φ60	45	43	142	231	296	156